

Overview 1
Hardware Setup 3
 Configuration 3
 Power 3
Charging the Battery Module 5
DBK30A – Specifications 6



Reference Notes:

- Refer to [Chapter 2, Power Management](#), in regard to calculating system power requirements.
- [Chapter 3, System Connections and Pinouts](#), includes pinouts for P1, P2, P3, and P4. Refer to the pinouts that are applicable to your system, as needed.

Overview

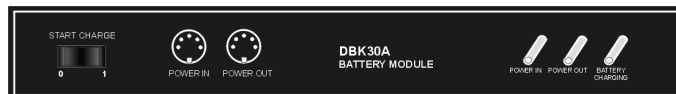

DBK30A Front Panel

DBK30A contains two rechargeable nickel-cadmium batteries and shares the same base dimensions as other LogBook, DaqBook, and related DBK module products, allowing for convenient stacking with included splice plates and dual-lock tabs.

The included power adapter converts AC power to 24 VDC for charging DBK30A's two battery packs. Automatic charging circuits recharge the internal batteries quickly and safely when connected to the supplied AC adapters. For trouble-free operation you must fully charge the batteries before use. The charged battery runtime depends on the current load and mode of operation.

An internal slide switch (SW2) determines the unit's mode. The two modes are:

- **14 VDC Mode (default)**
- **28 VDC Mode**



You should check the power requirements of each component in your system, and then verify that the power source can provide sufficient power to meet your runtime requirements.



Fully charge DBK30A's batteries before use.

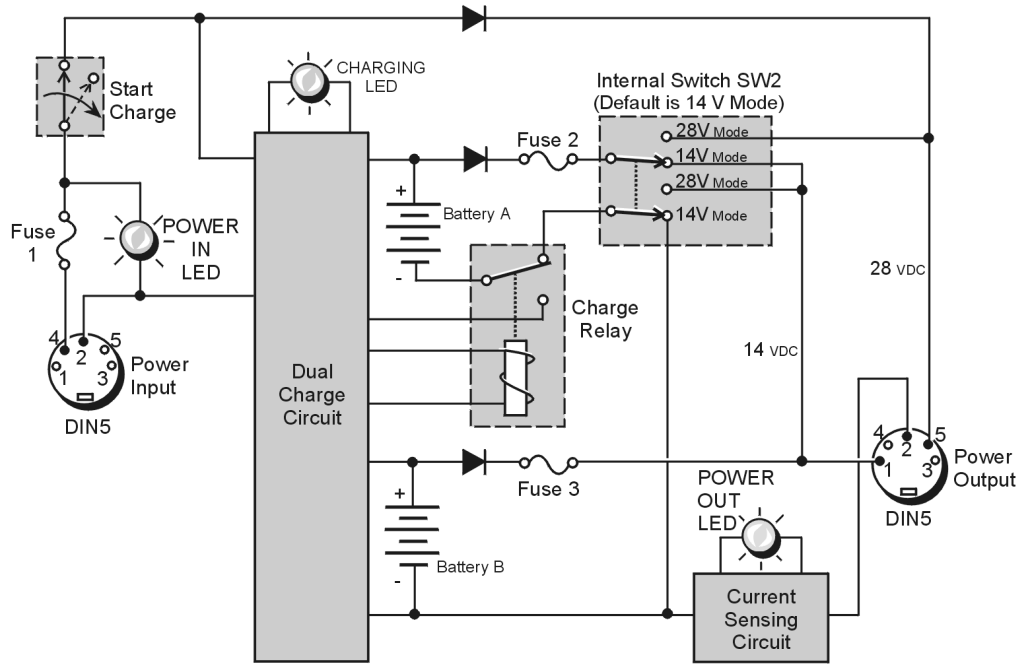

DBK30A Block Diagram

14 VDC Mode (default)

This mode provides 14 VDC for 3.4 A-hr. The typical battery runtime is from 3 to 6 hours depending on the load. Unless 28 VDC is required, the 14 VDC mode should be used in your LogBook applications.



Unless you need 28 V, leave the unit in the 14 VDC mode. Use of the 28 VDC mode results in a lower runtime, as only one battery pack can be used for 14 VDC. When in the 14 VDC mode, both packs are used in parallel, resulting in a longer runtime for the same application.

28 VDC Mode

The 28 VDC mode actually provides *both* 14 VDC *and* 28 VDC. Loop currents for two-wire, 4-20 mA transmitters (1.7 A-hr) require 28 VDC. The battery run-time typically ranges from 1 to 6 hours, depending on system configuration. In this mode, 14 VDC is used for unregulated bridge excitation (for bridge-configured sensors, such as load cells), and power to DBK expansion products.



Unless you need 28 V, leave the unit in the 14 VDC mode. Use of the 28 VDC mode results in a lower runtime, as only one battery pack can be used for 14 VDC. When in the 14 VDC mode, both packs are used in parallel, resulting in a longer runtime for the same application.

Hardware Setup

Configuration

The only configuration option is the choice of modes (**14 VDC**, or **28 VDC**). If you do not need 28 V, leave SW2 in the default position.



If you are using a pre-owned DBK30A, or are unsure of the mode selected, use the following steps to check SW2's position. Note that new units are always shipped with SW2 selected to the 14 VDC mode.

Internal switch SW2 is located on the printed circuit board, near the front center of the unit. To change or verify the mode:

1. Remove DBK30A's cover by removing one screw and sliding the cover forward until it separates from the module.
2. Look near the front center of the circuit board and locate slide switch SW2.
3. Check SW2's selection. The silkscreen indicates the 14 and 28 VDC positions.
4. Change the selection, if required. If you do not need 28 V, SW2 should be in the default position (14 VDC).
5. Replace the top cover, and secure with screw.

Power

Connection. The figure shows the pinout for the POWER OUT DIN5 connector. The 28 V pin is only active in the 28 VDC mode; however, the 14 V pin is active regardless of the mode selected.

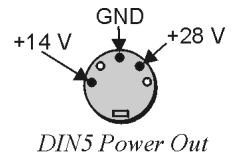

Cable CA-115 is included in the DBK30A package. The cable connects to DBK30A's POWER OUT connector and a LogBook, DaqBook, or WaveBook DIN5 POWER IN connector. The cable can be used to daisy-chain a DBK30A unit to a DBK or WBK expansion module.

The DBK30A package includes a short connecting cable (CA-115) to connect to the LogBook or Daq device. This cable connects the POWER OUT connector on the DBK30A to the POWER IN connector on the Daq device or LogBook (see next figure).

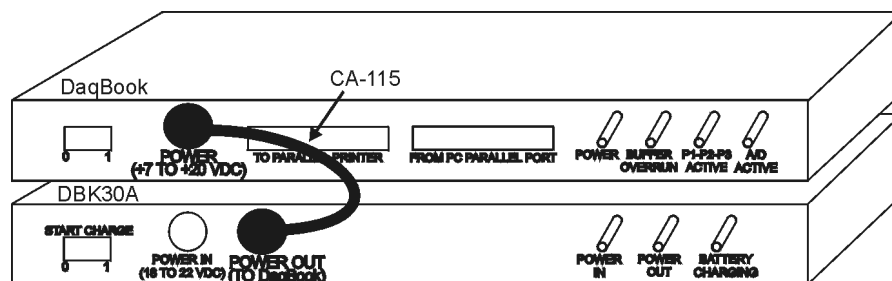

DBK30A to DaqBook Connection

28 VDC Mode. The primary purpose of the 28 VDC mode is to provide power for external loop transmitters. The hookup is simple, as shown below.

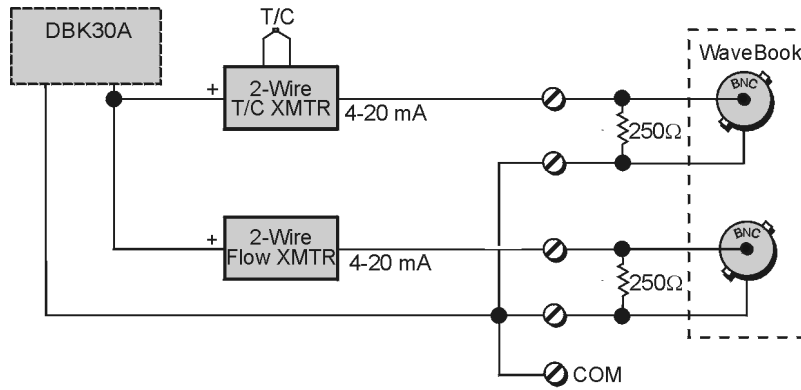

Connecting Loop Transmitters

Another use of the 28 VDC mode is to provide excitation for bridge-type sensors, such as load cells (strain gages).

The primary purpose of the 28 VDC mode is to power external user-supplied loop transmitters. The hookup is simple, as shown below. A DIN5 connector allows easy connection of lead wires.

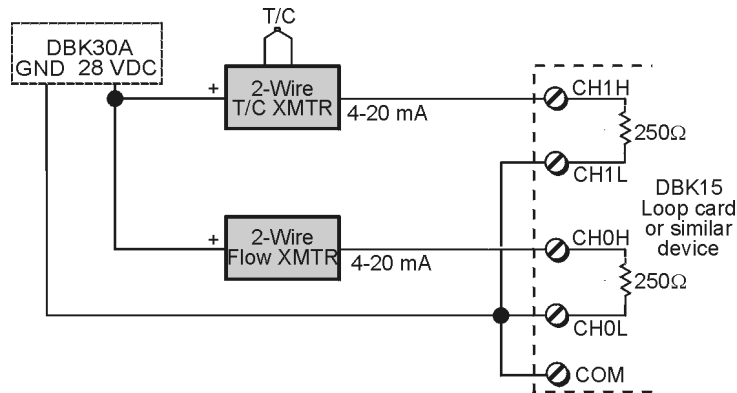

Connecting Loop-Transmitter Wires

The 28 VDC mode can also be used to provide a 14 VDC excitation source for bridge-type sensors such as load cells (strain gages). The excitation voltage is not regulated by the DBK30A; so, this voltage must be externally regulated to 10.00 V for most load cells.

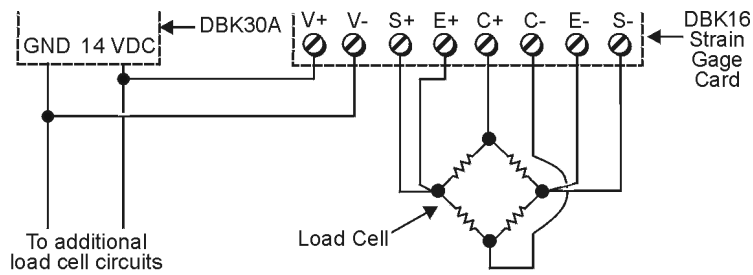

Using Load Cells



Excitation voltage from DBK30A is not regulated by the unit, and must therefore be regulated externally. For most load cells, excitation voltage should be regulated to 10 V.

Charging the Battery Module

To charge the DBK30A batteries:

1. Connect the adapter to DBK30A's POWER IN connector.
2. Plug the adapter into the AC power receptacle.

Note: The charge cycle will begin automatically whenever AC power is applied after an interruption. The charge cycle will automatically end when the batteries are fully charged.

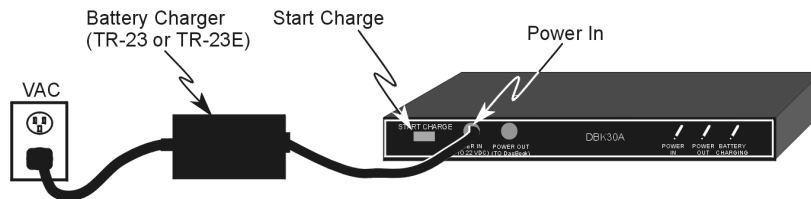

Charging DBK30A's Batteries

3. To manually initiate a charge cycle, press the START CHARGE momentary rocker-arm switch. Note that subsequent charge cycles applied to a fully-charged DBK30A will have no ill effect. The module will sense the fully-charged status and revert to the trickle-charge state within a few minutes.

Three LEDs on the DBK30A provide status information on the charging process or the external load.

LED Indicators & Descriptions	
POWER IN	Indicates the charger is connected to a source of AC power and to the battery module.
BATTERY CHARGING	Steady Light - Indicates the battery is in the high-current (2 A) charge mode. Flashing - One or two flashes at a time indicates the batteries are fully charged.
POWER OUT	Indicates power is flowing out to an external device.

CAUTION



Periodically, fully discharge the DBK30A to inhibit “lazy chemistry” (memory) in the nickel-cadmium cells. To manually discharge a battery pack, connect the primary acquisition device, e.g., WaveBook, DaqBook, or LogBook, to the DBK30A and leave it powered-on until the indicator lights go out.

Use While Charging.

- Both operating modes are capable of powering data acquisition devices while the DBK30A is being charged; however, the charging current will be reduced, and the charging time will increase.
- If AC power is interrupted, a new charge cycle will begin automatically when AC power returns.

CAUTION



Even with the AC adapter, the batteries will eventually discharge under an operating load. Charging DOES NOT BEGIN AUTOMATICALLY (except on power-up). You must manually initiate the next charge cycle. Do not expect a device powered by a DBK30A to operate as if connected to an uninterruptable power supply.

DBK30A – Specifications

Name/Function: Rechargeable Battery Module

Battery Type: Nickel-cadmium

Number of Battery Packs: 2

Battery Pack Configuration: 12 series-connected sub-C cells

Output Voltage: 14.4 V or 28.8 V (depending on the selected mode)

Output Fuses: 2 A

Battery Amp-Hours: 3.4 A-hr (1.7 A-hr/pack)

Charge Termination: Peak detection

Charge Time: 2 hours

Charging Voltage from Supplied AC Adapter: 22 to 26 VDC @ 2 A

AC Adapter Input: 95 to 265 VAC @ 47 to 63 Hz

Size: 221 mm × 285 mm × 35 mm (11" × 8-1/2" × 1-3/8")

Weight: 2.4 kg (6 lb)